

- **Unrivalled flow performance**
– $\pm 0.2\%$ accuracy.
- **Pulsed DC Technology Incorporates Benefits of AC Systems**
- **Operable flow range of 1000:1.**
- **For all process liquids and slurries**
- **Two-year warranty.**
- **Submersible and buriable sensors.**
- **FM approved and CSA certified for hazardous locations.**
- **Variety of corrosion and abrasion resistant materials of construction.**
- **Bi-directional flow metering system.**
- **Designed, manufactured and calibrated to internationally accepted standards**
 - ISO 9001/NAMAS/NIST/NATA
 - insures reliable, maintenance-free operation
- **CalMaster insuito verification system enabled**

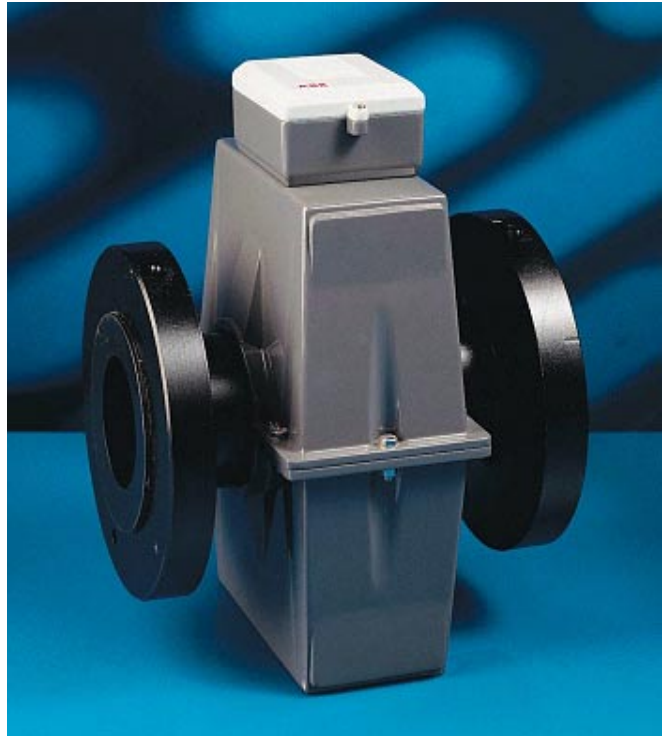

MagMaster MFE
Electromagnetic Sensors

INTRODUCTION

MAGMASTER flowmeters provide new levels of flow measurement and performance with an exclusive sensor design featuring ultra-linear magnetics and a patented signal processing system. The MagMaster utilizes pulsed dc technology coupled with the benefits of ac design.

Two modes – Process MAGMASTER and Slurry MAGMASTER are available in a wide range of sizes and options including electrode materials, liner materials and transmitter capabilities.

SPECIFICATIONS

Configuration:

Transmitter may be integral with sensor for sizes 1/2 to 16-inches (400mm) or remote from sensor for all sizes.

Separation (remote transmitters):

The maximum cable length in feet is the lower of 330 feet. Longer lengths are special order.

Accuracy (under forward flow reference conditions) with MagMaster Transmitter

Flanged sensors:

Display, Serial comms, Frequency output:

$\pm 0.2\%$ of reading or ± 0.003 ft/sec (0.001m/s) (whichever is greater) up to a maximum velocity of >49 ft/sec (15m/s). See Figure below.

Analog output:

As Frequency output plus ± 0.008 mA.

Pressure effect:

Less than 0.15% over the operating range of the instrument.

Temperature effect:

Sensor: $< \pm 0.03\%$ of rate per 10°C .

Repeatability & Reproducibility:

$\pm 0.05\%$ or ± 0.0008 ft/s (± 0.25 mm/s), whichever is greater.

Conductivity:

Liquids and slurries having a conductivity of not less than $5\mu\text{S/cm}$ ($5\mu\text{mho/cm}$).

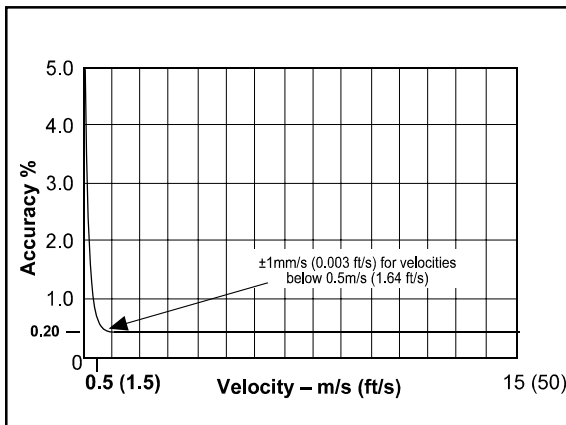

Mounting:

Directly into pipeline at any attitude. Electrodes can not be in vertical plane. Flow must be up if installed in a vertical pipe.

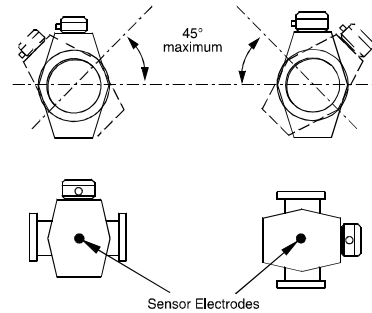

Recommended Mating Pipe Conditions:

Upstream: 5 to 10 diameters straight pipe depending on performance requirements and upstream disturbance.

Downstream: 2 to 3 diameters straight pipe depending on performance requirements and downstream disturbances.

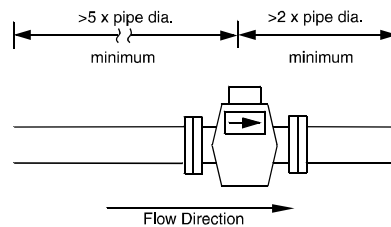

Power consumption:

Less than 20VA with transmitter.

Hazardous Area Certification:

FM approved and CSA certified for Class I, Div. 2, Groups A, B, C, D hazardous locations, 0.5-24 inches (15-600 mm).

NOTE: FM approved sensors for hazardous locations include an intrinsic safety shunt circuit for the electrodes allowing for a Div. 1 rating inside the pipe. The circuit is located in the larger than standard terminal box housing. CSA certified sensors for hazardous locations may or may not include the circuit, depending on the rating inside the pipe.

Calibration:

3 point, 8 point, witnessed, NIST/NAMAS (8- to 24-inch only), slurry calibration options. Calmaster fingerprinting.

Sensor cable connection:

0.5 inch NPT--single opening. A single cable is available that provides for the coil drive and electrode signals. See Options.

SPECIFICATION – SENSORS

MAGMASTER sensors are available in flanged styles and come in a wide choice of lining and electrode materials to satisfy all applications. (Refer to **Table B** for option details.)

Sizes (Nominal Bore):

1/2-inch to 24-inches (15mm to 600mm). Refer to MAG.PLUS specifications for larger sizes.

Metering Tube:

Lined stainless steel. (304 SST)

Lining:

PFA-Perfluoroalkoxy fluorocarbon – UKWFBS* (chemically resistant to almost all liquids), Elastomer - chlorobutylrubber and EPDM – UKWFBS*, Polypropylene – UKWFBS*, Polyurethane and Neoprene. Polyurethane meeting FDA approval also available for potable water

* *United Kingdom Water Fittings Bylaws Scheme (UKWFBS) listed for potable water.*

Electrodes:

Non-removable, 316 S.S, Hastelloy C, Titanium, Tantalum and Platinum/Iridium. Treated titanium for pulp and paper applications where concentrations of stock are greater than 5% or liquid contains long fibers regardless of the concentration. Tungsten carbide coated electrodes for high abrasion mining, cement or flyash applications.

Grounding Electrode:

Fitted as standard in flanged meters, 1/2 in. to 6 in. (15 to 150 mm), in the same material as measuring electrodes.

Note: Pressure Limitations

Flanged meters:
Sizes 0.5-inch to 24-inch (15mm to 600mm):
maximum pressure dictated by flange rating.

Process Connections:

Flanged meter-Carbon steel flanges to mate with BS4504, DIN, UNI, AFNOR, ANSI, AS2129 and BS10 flanges.

Temperature:

Sensors (with integral transmitters):

Ambient: -10 to +60°C (14 to 140°F)

Process Fluid:

Polyurethane lining: -10 to +70°C (14 to 158°F)

All other linings: -10 to +80°C (14 to 176°F)

Ambient and process fluid is limited to -10° to 60°C for the integral CSA-certified hazardous area meter

Sensors (remote transmitter): see **Table A**.

Environmental Protection:

Sensors with integral transmitters:

NEMA 4X/IP65

Flanged sensors, with remote transmitters*:

NEMA 6P/IP68 with potted terminal box and cable - up to 33 ft (10 M) depth.

Buriable:

3 ft. (1m) to 16 ft. (5m) depth (to top of sensor).

*NOTE: All remote sensors are supplied with potting compound for sealing on-site or can be ordered with cable connected to sensor and terminal box potted.

Sensor Housing:

Flanged meters:

1/2 to 6-inch (150mm) Cast aluminum alloy, Epoxy coated.

Approved/certified & High temperature meters:

8- to 24-inch (200 to 600mm) Fabricated steel.

Table A Temperature Limits for Sensors (Remote Transmitter) at -30 to 140°F (-35 to 60°C) Ambient

Sensor Construction	Liner Material vs Process Fluid Temperature Maximum (°C/°F)				
	Poly-propylene	FEP/PFA "Teflon" & Elastomer	Ebonite	Poly-urethane	Neoprene
ABB Standard, Non-hazardous, 1/2" to 6", metal cased 8" to 24"	26.6/80	120/248	95/203	70/158	110/230
FM approved, CSA certified, Non-Hazardous, high temp., 1/2" to 24"	26.6/80	120/248	95/203	70/158	110/230
FM approved, CSA certified, Hazardous, high temp., 1/2" to 24"	26.6/80	120/248*	95/203	70/158	110/230*
FM approved, CSA certified, Non-Hazardous, 1/2" to 24"	26.6/80	80/176	80/176	70/158	80/176
FM approved, CSA certified, Hazardous, standard temp., 1/2" to 24"	26.6/80	60/140	60/140	60/140	60/140

* Note: 8- to 24-inch (200 –600mm) sizes limited to 100°C (212°F)

TEFLON® is a registered trademark of the E.I. DuPont de Nemours & Co.

Hastelloy® is a registered trademark of Haynes International, Inc.

DIMENSIONS

1/2- to 6-inch (15 to 150mm) flanged sensors without transmitter or terminal box

Meter Size		A		B		C		Net Weight	
mm	inch	mm	inch	mm	inch	mm	inch	kg	lbs
15	0.5	174	6.9	140	5.5	200	7.9	9	20
20	0.75	174	6.9	140	5.5	200	7.9	9	20
25	1.0	210	8.3	176	6.9	200	7.9	10	22
40	1.5	210	8.3	176	6.9	200	7.9	12	27
50	2.0	210	8.3	176	6.9	200	7.9	14	31
65	2.5	280	11.0	219	8.6	200	7.9	19	42
80	3.0	280	11.0	219	8.6	200	7.9	20	44
100	4.0	312	12.3	230.5	9.1	250	9.9	28	62
150	5.9	370	14.6	281	11.1	300	11.8	39	86

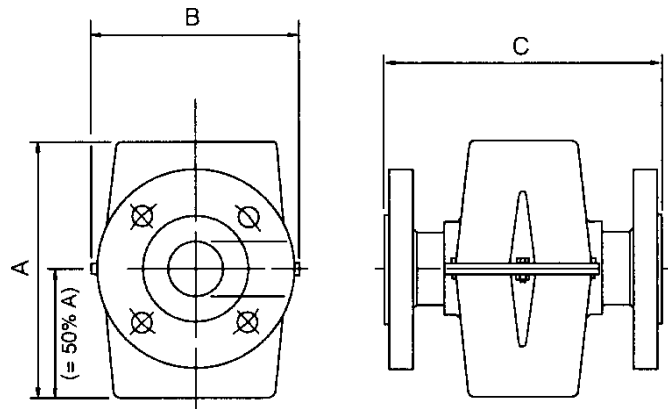

Polyurethane and PFA are part face linings

DIMENSIONS

8- to 24-inch (200 to 600mm) flanged sensors without transmitter or terminal box

Meter Size		A		B		C (w/liners)		Net Weight	
mm	inch	mm	inch	mm	inch	mm	inch	kg	lbs
200	8	400	15.7	396	15.6	418	16.5	52	115
250	10	446	17.6	455	17.9	488	19.2	80	176
300	12	508	20.0	510	20.1	538	21.2	108	238
350	14	560	22.0	562	22.1	568	22.4	120	264
400	16	614	24.2	596	23.5	618	24.3	186	410
450	18	656	25.8	640	25.2	698	27.5	210	462
500	20	710	28.0	700	27.6	768	30.2	266	586
600	24	810	31.9	810	31.9	918	36.1	378	832

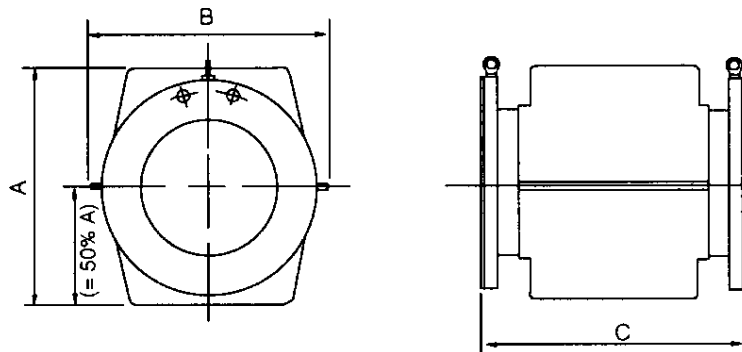

Polyurethane and FEP are part face linings

Table B Flowmeter Sizing

Size		USGPMs				
mm	Inches	Operable Minimum Flow	Flow Rate Deviation See Note 1	Minimum Flow at Rated Accuracy	Maximum Flow @ 10 m/s (33 ft./sec)	Std. Calibrated Range See Note 2
15	0.5	0.03	0.003	1.4	28	10
20	0.75	0.05	0.005	2.5	49	15
25	1	0.08	0.008	3.9	77	25
40	1.5	0.20	0.020	10.0	199	60
50	2	0.31	0.031	15.6	311	100
65	2.5	0.53	0.053	26.3	525	150
80	3	0.80	0.080	39.8	796	225
100	4	1.24	0.12	62.2	1244	400
150	6	2.80	0.28	140	2800	900
200	8	4.98	0.50	249	4980	1500
250	10	7.78	0.78	389	7780	2000
300	12	11.2	1.12	560	11,202	3000
350	14	15.2	1.5	762	15,248	4000
400	16	19.9	2.0	996	19,916	5000
450	18	25.2	2.5	1260	25,209	6000
500	20	31.1	3.1	1556	31,122	7500
600	24	44.8	4.5	2240	44,812	10,000

Note 1: Flow rate deviation listed is the plus and minus inaccuracy in terms of USGPM for all flows below the **Minimum Flow at Rated Accuracy** column. These values apply to the pulse/frequency/displayed output of flanged meters.

Note 2: The transmitter is set to this range for the 4-20 mA output unless otherwise specified.

Model Number Designation

	MF/E														
	04	05	06	07	08	09	10	11	12	13	14	15	16	17	18
Bore Size															
0.5 in (15mm)					E150										
0.75 in (20mm)					E200										
1.0 in (25mm)					E250										
1.5 in (40mm)					E400										
2.0 in (50mm)					E500										
2.5 in (65mm)					E650										
3.0 in (80mm)					E800										
4.0 in (100mm)					E101										
6.0 in (150mm)					E151										
8.0 in (200mm)					E201										
10.0 in (250mm)					E251										
12.0 in (300mm)					E301										
14.0 in (350mm)					E351										
16.0 in (400mm)					E401										
18.0 in (450mm)					E451										
20.0 in (500mm)					E501										
24.0 in (600mm)					E601										
Flange Style End Connections															
Standard, Flanged ANSI Class 150 compatible, Fully rated															3
Flanged ANSI Class 300 compatible, Fully rated, 8 to 24 inch.															K
Lining Materials															
Teflon bonded FEP, 8 through 24 inches (200mm-600mm)															
8 inch thru 24 inch															3
Elastomer, 2 through 24 inches (50mm -600mm)															4
Polyurethane, 1 through 24 inches (25mm -600mm)															6
Teflon (PFA), 0.5 through 6 inches (15mm -150mm)															7
Neoprene, 8 through 24 inches (200mm -600)															8
Electrodes															
316 Stainless Steel															1
Hastelloy C															2
Titanium															3
Tantalum .5 through 6 inches (15mm-150mm)															4
Tantalum, ≥8 inches (≥200mm)															4
Platinum/Iridium .5 through 6 inches (15mm-150mm)															5
Platinum/Iridium ≥8 inches (≥200mm)															5
Tungsten Carbide Coated 316SST (For Mining, Cement, Flash applications)															6
Treated Titanium Slurry Electrode (only with slurry calibration & slurry mode transmitter)															8
316 Stainless Steel, Slurry Calibration															A
Hastelloy 'C', Slurry Calibration															B

	MF/E	04	05	06	07	08	09	10	11	12	13	14	15	16	17	18
Sensor Construction																
ABB standard. Non-hazardous location. 1 in. through 6 in.(15mm-150mm)										1						
ABB standard. Non-hazardous location. Metal case for 8 through 24 inches (200mm-600mm)										4						
High temperature process fluid temperature above 140°F (60°C) FM approved, CSA certified non-incendive for Class I, Div 2, Groups A, B, C, D hazardous locations, intrinsically safe electrodes, remote sensor only										6						
Process fluid temperature 140°F (60°C) maximum. 0.5 through 24inches (15mm-600mm)										7						
FM approved, CSA certified non-incendive for Class I, Div 2, Groups A, B, C, D hazardous locations, intrinsically safe electrodes, remote sensor only.										8						
High temperature process fluid temperature above 140°F (60°C) 0.5 through 24 inches (15mm-6000mm)										7						
FM approved, CSA certified for non-hazardous locations. Standard temperature range 0.5 through 24inches (15mm-600mm)										8						
FM approved, CSA certified for non-hazardous locations. High temperature process temperature above 140°F (60°C). Remote only. 0.5 through 24 inches (15mm-600mm)										D						
CSA certified non-incendive for Class I, Div 2, Groups A, B, C, D hazardous locations. Non-incendive electrodes. Process fluid temperature 140°F (60°C) maximum. 0.5 through 24 inches (15mm-600mm)										A						
CSA certified non-incendive for Class I, Div 2, Groups A, B, C, D hazardous locations. Non-incendive electrodes. High temperature process fluid temperature above 140°F (60°C). Remote only. 0.5 through 24 inches (15mm-600mm)										B						
Accessories																
None										0						
Grounding ring (one piece) (0.5" through 24")										1						
Grounding ring (two piece) (0.5" through 24")										8						
Calibration																
Standard 3-point calibration										1						
8-point calibration - 0.5 through 6 inches (15mm-150mm), ≥8 inches (200mm)										2						
Custom calibration										9						
CalMaster Fingerprint w/3-point calibration										J						
Unused														00		
Glanding																
Conduit entry: 0.5" NPT - order cable and length per OPTIONS														4		
Conduit entry: 0.5" NPT - cable fitted and potted - order cable and length per OPTIONS														8		
Transmitter Type																
Sensor built for integral mounted MagMaster transmitter (≤ 16" only)																EH
Sensor built for Remote MagMaster transmitter																ER
Instruction Manual																IM/MAG/MAS
OPTIONS (specify as separate item on order)																
Cable, sensor/transmitter (list number of feet)																
Standard. <u>Can be used</u> with FM/CSA approved instruments.																STT3350
Submersible-Waterproof. <u>Cannot be used</u> with FM/CSA approved instruments.																STT3500
Armored. <u>Cannot be used</u> with FM/CSA approved instruments.																STT3501

Notes:

1. FM approved, CSA certified sensors or transmitter must be part of an approved/certified MAGMASTER system.
2. Use a "9" in the catalog number to signify special feature in the character position (to be used with an Special Product Request SPR number).
3. Consult factory for other materials of construction.

CF = Consult Factory

Notes

ABB has Sales & Customer Support
expertise in over 100 countries worldwide

www.abb.com

The Company's policy is one of continuous product
improvement and the right is reserved to modify the
information contained herein without notice.

Printed in USA (05.09.03)

© ABB 2003



ABB Inc.
125 East County Line Road
Warminster
PA 18974
USA
Tel: +1 215 674 6000
Fax: +1 215 674 7183

ABB Ltd
Howard Road, St. Neots
Cambridgeshire
PE19 8EU
UK
Tel: +44 (0)1480 475321
Fax: +44 (0)1480 217948

**ABB Automation Products
GmbH**
Dransfelder Str. 2.
37079 Goettingen
Germany
Tel: +49 551 905-0
Fax: +49 551 905-777