

MODEL M0300

BOLT-ON SADDLE FLOWMETER

DESCRIPTION

The M0300 Bolt-On Saddle Flowmeter features a fabricated stainless steel saddle with McCrometer's unique drive and register design. The stainless steel saddle eliminates the fatigue-related breakage common to cast iron and aluminum saddles and provides unsurpassed corrosion protection. Fabricated stainless steel construction offers the additional advantage of being flexible enough to conform to out-of-true pipe. The Model M0300 is manufactured to comply with applicable provisions of American Water Works Association Standard No. C704/92 for propeller-type flowmeters. As with all McCrometer propeller flowmeters, standard features include a magnetically coupled drive, instantaneous flowrate indicator and straight reading, six-digit totalizer.

Impellers are manufactured of high-impact plastic, capable of retaining their shape and accuracy over the life of the meter. Each impeller is individually calibrated at the factory to accommodate the use of any standard McCrometer register, and since no change gears are used, the M0300

can be field-serviced without the need for factory recalibration. Factory lubricated, stainless steel bearings are used to support the impeller shaft. The shielded bearing design limits the entry of materials and fluids into the bearing chamber providing maximum bearing protection.

The instantaneous flowrate indicator is standard and available in gallons per minute, cubic feet per second, liters per second and other units. The register is driven by a flexible steel cable encased within a protective vinyl liner. The register housing protects both the register and cable drive system from moisture while allowing clear reading of the flowrate indicator and totalizer.

INSTALLATION

Standard installation is horizontal mount. If the meter is to be mounted in the vertical position, please advise the factory. A straight run of full pipe the length of five diameters ahead and one diameter behind the meter is the minimum normally recommended.



The McCrometer Propeller flowmeter comes with a standard instantaneous flowrate indicator and straight-reading totalizer. An optional electronic register is also available. *Typical face plates.*

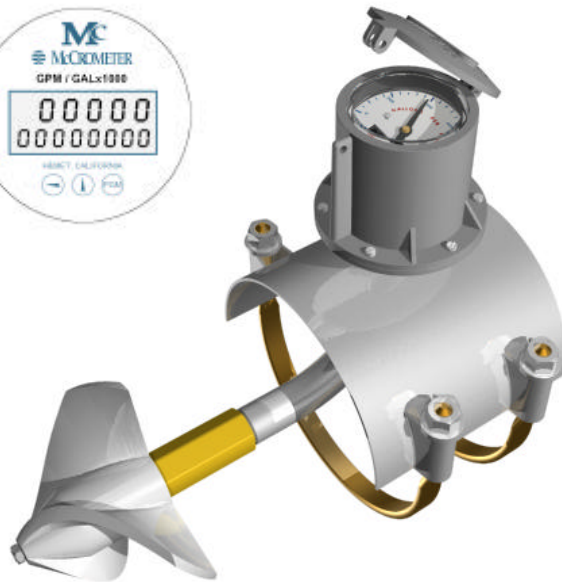

APPLICATIONS

- Center pivot systems
- Sprinkler irrigation systems
- Drip irrigation systems
- Golf course and park water management
- Gravity turnouts from underground pipelines
- Commercial nurseries
- Water and wastewater management

BOLT-ON SADDLE METER M0300

SPECIFICATIONS

PERFORMANCE

ACCURACY/REPEATABILITY: ±2% of reading guaranteed throughout full range; ±1% over reduced range; Repeatability 0.25% or better

MAXIMUM TEMPERATURE: (Standard Construction) 160°F constant

PRESSURE RATING: 150 psi

MATERIALS

BEARING ASSEMBLY: Impeller shaft is 316 stainless steel. Ball bearings are 440C stainless steel.

MAGNETS: (Permanent type) Cast or sintered Alnico

BEARING HOUSING: Brass; Stainless Steel optional

SADDLE: 304 stainless steel construction

REGISTER: An instantaneous flowrate indicator and six-digit straight-reading totalizer are standard. The register is hermetically sealed within a die cast aluminum case. This protective housing includes a domed acrylic lens and hinged lens cover with locking hasp.

IMPELLER: Impellers are manufactured of high-impact plastic, retaining their shape and accuracy over the life of the meter. High temperature impeller is optional.

OPTIONS

- Saddle can be constructed to fit any outside diameter pipe dimensions, including metric sizes
- Can be used on a variety of pipe materials such as steel, plastic, cast iron, cement or asbestos cement
- Register extensions
- All stainless steel bearing assembly
- High temperature construction
- "Over-Run" bearing assembly for higher than normal flowrates
- Electronic propeller meter available in all sizes of this model
- A complete line of flow recording / control instrumentation
- Blank repair saddle

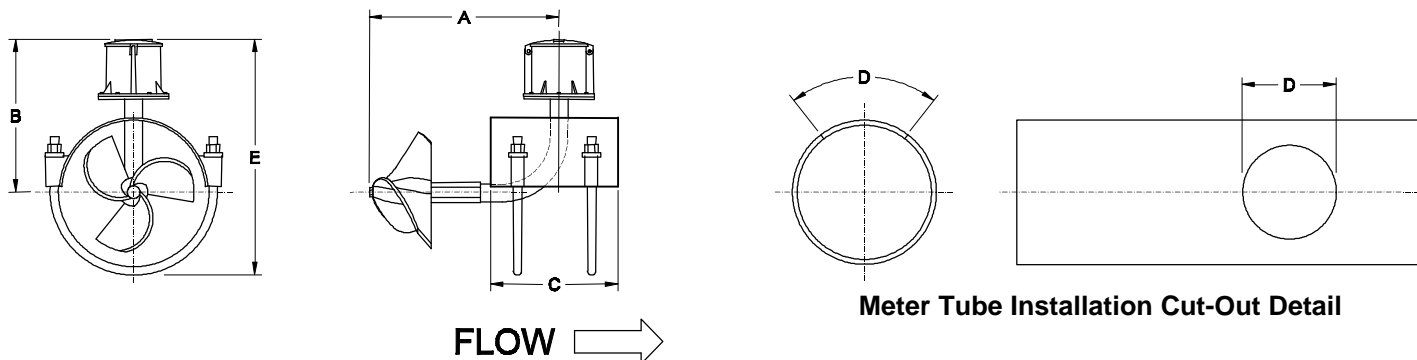

M0300	DIMENSIONS						
Meter and Nominal Pipe Size	4"	6"	8"	10"	12"	14"	16"
Maximum Flow U.S. GPM	600	1200	1500	1800	2500	3000	4000
Minimum Flow U.S. GPM	50	90	100	125	150	250	275
Approx. Head Loss in Inches at Max. Flow	23.00	17.00	6.75	3.75	2.75	2.00	1.75
Approx. Shipping Weight-lbs.	18	22	26	30	34	38	44
A (inches)	7 5/8	15	15	15	15	15	15
B (inches)	8 1/4	10 3/4	10 3/4	10 3/4	11 3/4	13 3/4	13 3/4
C (inches)	7	8	8	9 1/2	9 1/2	9 1/2	9 1/2
D (inches)	4*	5 1/8*	6*	7*	7 1/4	7 1/4	7 1/4
E (inches)	10 3/4	14	15	17	19	20 5/8	21 5/8

For larger sizes see Model M1400.

McCrometer reserves the right to change design or specification without notice.

**Standard pipe only. For other than standard pipe, consult factory for cutout dimensions.*

FOR MORE INFORMATION CONTACT:



3255 West Stetson Avenue
 Hemet CA 92545-7799 USA
 909-652-6811 / FAX 909-652-3078
 e-mail: info@mccrometer.com
 Web Site: http://www.mccrometer.com