

**MODEL ML-11X-D**

150 psi REPLACEMENT METER HEAD ASSEMBLY
SOLID STATE ELECTRONIC PROPELLER METER
DIGITAL INDICATOR - TOTALIZER
SIZES 6" thru 72"

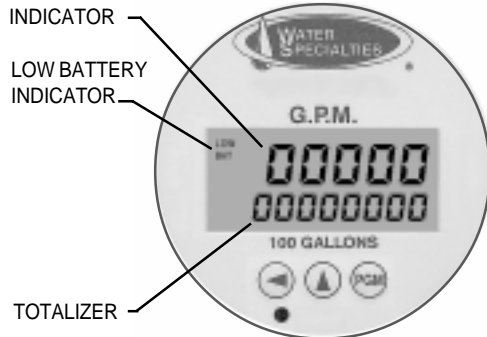

TYPICAL
DIGITAL INDICATOR-TOTALIZER

**DESCRIPTION**

MODEL ML-11X-D METER HEAD ASSEMBLIES are manufactured to the highest standards. Materials used on all meters and flow ranges for the low velocity meter meet, or exceed, AWWA standard C704. The bolt-on design permits use in a wide range of existing applications with up to 150 psi working pressure. It is necessary, upon ordering, to furnish the I.D. dimension of the pipe the meter is to be mounted on for calibration purposes, and the saddle dimensions from the back of the data sheet. It may be necessary to modify or remove the existing straightening vanes to allow proper clearance for Water Specialties three bladed propeller (see propeller dimension on back of data sheet).

INSTALLATION is made by bolting the meter head assembly to the existing saddle or meter tube. The meter can be installed horizontally, or inclined, on suction or discharge lines. The meter must have a full flow of liquid for proper accuracy. Fully opened gate valves, fittings or other obstructions that tend to set up flow disturbances should be a minimum of ten pipe diameters upstream and two pipe diameters downstream from the meter. Installations with less than ten pipe diameters of straight pipe require straightening vanes. Meters with straightening vanes require at least five pipe diameters upstream and one pipe diameter downstream of the meter. An optional kit of adapters and up to 100 feet of cable is available to locate the indicator-totalizer at remote locations.

PROPELLER is magnetically coupled with the electronic sensor through the sealed gearbox. This completely eliminates water entering the meter assembly, and eliminates all moving parts except for the propeller. The propeller is a conical shaped three bladed propeller, injection molded of thermoplastic material resistant to normal water corrosion and deformity due to high flow velocities.

BEARING in propeller is a water lubricated ceramic sleeve and spindle bearing system with a ceramic/stainless steel spindle. Dual ceramic thrust bearings, standard on all meters, handle flows in both forward and reverse directions. The bearing design promotes extended periods of maintenance free propeller operation.

DIGITAL INDICATOR-TOTALIZER has a non-volatile EEPROM memory to store totalizer count (updated every 60 minutes while running). The indicator dial can be furnished in GPM, CFS, MGD or any standard liquid measuring unit with a choice of totalizer measuring units. The display is programmable to update from 0.5 to 5 seconds, and timeout from 1 to 9999 seconds.

INDICATOR (rate) FUNCTION is a five digit indicator with .35" tall numbers, programmable with 0 to 4 decimal point place with 0.0001 to 9999 rate scaling and totalizing factors. The calculation method is 1/Tau. It has programmable smoothing of 0 to 99%. The rate zero time is 8 seconds.

TOTALIZER FUNCTION is a eight digit totalizer with .20" tall numbers, programmable with 0 to 4 decimal places and a total scaling factor of 0.0001 to 9999. The totalizer can be reset from the front panel or disabled permanently.

O-RING SEALS are used at the meter head and all points where seals are required, making the sensor probe completely immune to any of the corrosive effects of atmospheric moisture or the liquids measured by the meter assembly.

SPECIFICATIONS

ACCURACY	Plus or minus 2% of actual flow within the range specified for each meter size.
PRESSURE RANGE	Up to 150 PSI maximum working pressure.
TEMPERATURE RANGE	140° F Maximum. Consult factory for special construction for higher temperatures.
MINIMUM FLOWS	As shown for each meter size and construction are required for accurate registration. See flow chart.
MAXIMUM FLOWS	As shown for each meter size and construction are rated for continuous operation. See flow chart.
INTERMITTENT FLOWS	As shown for each meter size are rated for 10% to 15% of the total time the meter is operating. Consult factory for High Velocity construction when intermittent flows are higher than shown on flow chart and/or when longer operating periods are required.
MATERIALS	Used in construction are chosen to minimize the corrosive effects of the liquids measured by the meter assembly. PROPELLER MAGNET - permanent ceramic type PROPELLER BEARING - ceramic sleeve type PROPELLER SPINDLE - ceramic coated stainless steel PROPELLER - injection molded thermoplastic GEARBOX - cast bronze SEPARATOR - stainless steel METER HEAD BOLTS - stainless steel (3" - 20") plated steel (24" - 72") METER HEAD - cast iron or fabricated steel, NSF approved, fusion epoxy coated.
OPTIONAL EQUIPMENT	Remote mounting kit with up to 100 feet of cable, totalizer extensions, digital transmitter, and a wide range of controls and instruments for indicating, totalizing and recording flow data for each meter. Special constructions and materials are available upon request.
ORDERING INFO	Must be specified by the customer and includes: Meter size, model number and serial number of the meter it is replacing Minimum & maximum flow ranges Temperature of meter environment Indicator scale & units Totalizer dial units Type of materials and construction Optional equipment desired

MODEL ML-11X-D

150 psi REPLACEMENT METER HEAD ASSEMBLY
 SOLID STATE ELECTRONIC PROPELLER METER
 DIGITAL INDICATOR - TOTALIZER
 SIZES 6" thru 72"

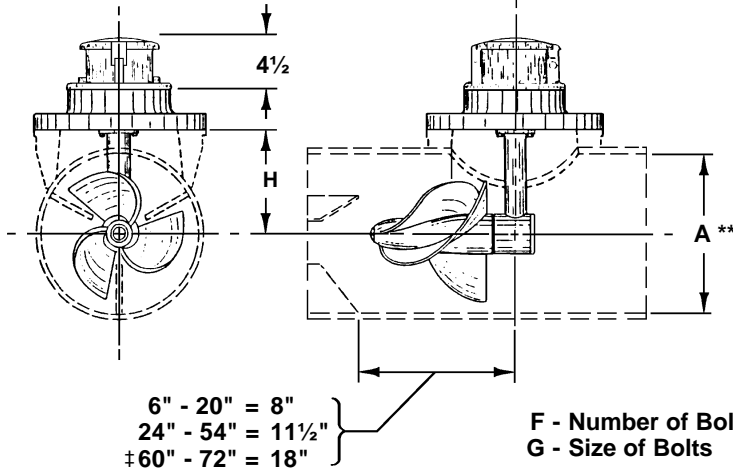

F - Number of Bolts
 G - Size of Bolts

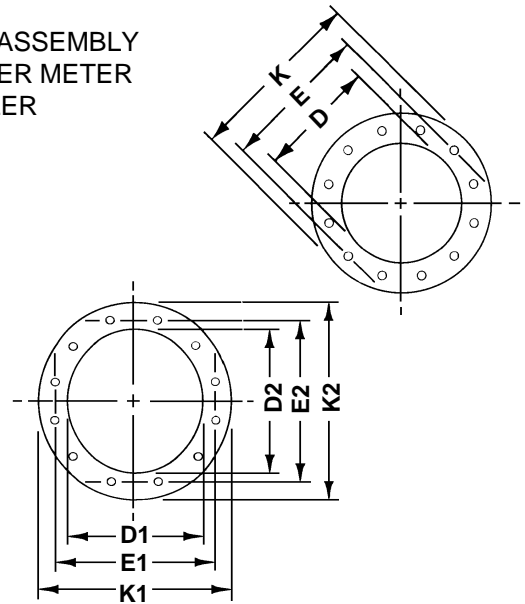

** PLEASE SPECIFY
 PIPE I.D. AND O.D.

NOTE: Existing straightening vanes may require modification or removal to allow proper clearance for Water Specialties three bladed propeller (see propeller dimension).

METER & PIPE SIZE	FLOW RANGES, GPM			DIMENSIONS							SHIPPING WEIGHT POUNDS
	*LOW VELOCITY CONSTRUCTION MIN. - MAX.	STANDARD CONSTRUCTION MIN. - MAX. - INT.	HIGH VELOCITY CONSTRUCTION MIN. - MAX.	A	(D1,D2) D	(E1,E2) E	F	G	H	K	
6	N/A	120-1200-1500	300-1500								35
8	N/A	150-1500-2000	400-2500								35
10	N/A	180-2000-3000	500-3500								45
12	N/A	200-3000-3500	800-5000								50
14	N/A	300-4000-4500	1000-6000								55
16	N/A	400-5000-6000	1200-7500								55
18	N/A	700-6000-7500	1500-9000								55
20	N/A	850-8000-9000	2000-12000								55
24	N/A	1000-10000-13500	3000-15000								190
30	N/A	1800-15000-21000	4000-25000								190
36	N/A	2000-20000-30000	5000-35000								190
42	N/A	3000-30000-40000	6000-50000								365
48	N/A	5500-35000-50000	7000-60000								365
54	3200-45000	6500-45000-55000	8000-65000								365
60	4000-60000	7500-60000-80000	10000-90000								365
66	4750-75000	8500-75000-95000	12000-105000								365
72	5500-90000	9500-90000-115000	15000-125000								365

Standard construction will be supplied for all main line meters unless special flow range, materials, or construction are required.

* Low velocity (LV) construction has the same low and maximum flow rates as AWWA C704.

† On 60-72 high velocity meters the propeller dimension is 11 1/2".

WATER SPECIALTIES

Visit our Website: www.waterspecialties.com
 E-Mail: info@waterspecialties.com

3255 WEST STETSON AVENUE • HEMET, CALIFORNIA 92545-7799 USA
 TEL: 909-652-0591 • FAX: 909-652-5592

Copyright © 2001 Water Specialties All printed material should not be changed or altered without permission of Water Specialties. The published technical data and instructions are subject to change without notice. Contact your Water Specialties representative for current technical data and instructions.