



**MODEL ML-03**  
 150 psi FLANGED TUBE METER  
 SEALED METER MECHANISM - MAGNETIC DRIVE  
 SEALED TOTALIZER  
 SIZES 2" thru 48"



TOTALIZER



## DESCRIPTION

**MODEL ML-03 FLANGED TUBE METERS** are manufactured to the highest standards. Materials used on all meters and flow ranges for the low velocity meter meet or exceed AWWA standard C704. The flanged end tube design permits use in a wide range of applications with up to 150 psi working pressure. Flanged ends are 150 lb. AWWA class D flat face steel flanges. Fabricated steel meter tubes have straightening vanes and are protected internally and externally with 12-15 mils of NSF approved, fusion bonded epoxy resin.

**INSTALLATION** is made similar to placing a short length of flanged end pipe in the line. The meter can be installed in any of the following positions: vertically, horizontally or inclined on suction or discharge lines. The meter must have a full flow of liquid for proper accuracy. Fully opened gate valves, fittings or other obstructions that tend to set up flow disturbances should be a minimum of five pipe diameters upstream and one pipe diameter downstream from the meter.

**PROPELLER** is magnetically coupled with the drive mechanism through the sealed oil filled gearbox. This completely eliminates water entering the meter assembly, as well as the need for any packing gland. The propeller is a conical shaped three bladed propeller, injection molded of thermoplastic material resistant to normal water corrosion and deformity due to high flow velocities.

**BEARING** in propeller is a water lubricated ceramic sleeve and spindle bearing system with a ceramic/stainless steel spindle. Dual ceramic thrust bearings, standard on all meters, handle flows in both forward and reverse directions. The bearing design promotes extended periods of maintenance free propeller operation. Bearings within the sealed meter mechanism are shielded precision stainless steel bearings and are factory lubricated for the life of the meter.

**TOTALIZER** is o-ring sealed and magnetically coupled with the driving mechanism, and features a six digit totalizer with a full 3" diameter, 100 division, center sweep dial that permits extremely accurate readings for timing purposes in determining flow rates. The totalizer dial can be furnished in gallons, cubic feet, acre feet or any standard liquid measuring units. The bonnet, with padlock hasp, can be positioned in four different directions for the easiest possible reading when the meters are mounted in unusual positions.

**CHANGE GEARS** may be easily exchanged in the field when changing the dial, or when recalibrating for different pipe sizes. It is not necessary to remove pressure from the line for these changes.

**O-RING SEALS** are used at the meter head and all points where seals are required, making the meter mechanism completely immune to any of the corrosive effects of atmospheric moisture or the liquids measured by the meter assembly.

## SPECIFICATIONS

**ACCURACY** plus or minus 2% of actual flow within the range specified for each meter size.

**PRESSURE RANGE** up to 150 PSI maximum working pressure.

**TEMPERATURE RANGE** 140° F Maximum. Consult factory for special construction for higher temperatures.

**MINIMUM FLOWS** as shown for each meter size and construction are required for accurate registration. See flow chart. NOTE: Minimum flow will be higher when auxiliary equipment is added.

**MAXIMUM FLOWS** as shown for each meter size and construction are rated for continuous operation. See flow chart.

**INTERMITTENT FLOWS** as shown for each meter size are rated for 10%-15% of the total time the meter is operating. Consult factory for High Velocity construction when intermittent flows are higher than shown on flow chart and/or when longer operating periods are required.

**MATERIALS** used in construction are chosen to minimize the corrosive effects of the liquids measured by the meter assembly.

MAGNETS are permanent ceramic type.

INTERIOR BEARINGS are shielded stainless steel.

PROPELLER BEARING is ceramic sleeve type.

PROPELLER SPINDLE is ceramic coated stainless steel.

PROPELLER is injection molded thermoplastic.

GEARBOX is cast bronze.

SEPARATOR and SHAFTS are stainless steel.

METER HEAD BOLTS are stainless steel on 2"-20" units and plated steel on 24"-48" units.

METER HEAD is cast iron or fabricated steel NSF approved, fusion bonded epoxy coated.

METER TUBE is fabricated steel with straightening vanes and coated, inside and out, with 12-15 mils of NSF approved, fusion bonded epoxy by the fluidized bed method.

**OPTIONAL EQUIPMENT** is available upon request, including totalizer extensions, special construction or materials and a wide range of controls and instruments for indicating, totalizing and recording flow data.

**A 5 YEAR GUARANTEE IS AVAILABLE FOR 2"-36" METERS.**

**ORDERING INFO** must be specified by the customer and should include minimum and maximum flow ranges, the temperature of the meter environment, the totalizer dial units required, the type of materials/construction needed and optional equipment desired.

**MODEL ML-03**

150 psi FLANGED TUBE METER  
 SEALED METER MECHANISM - MAGNETIC DRIVE  
 SEALED TOTALIZER  
 SIZES 2" thru 48"

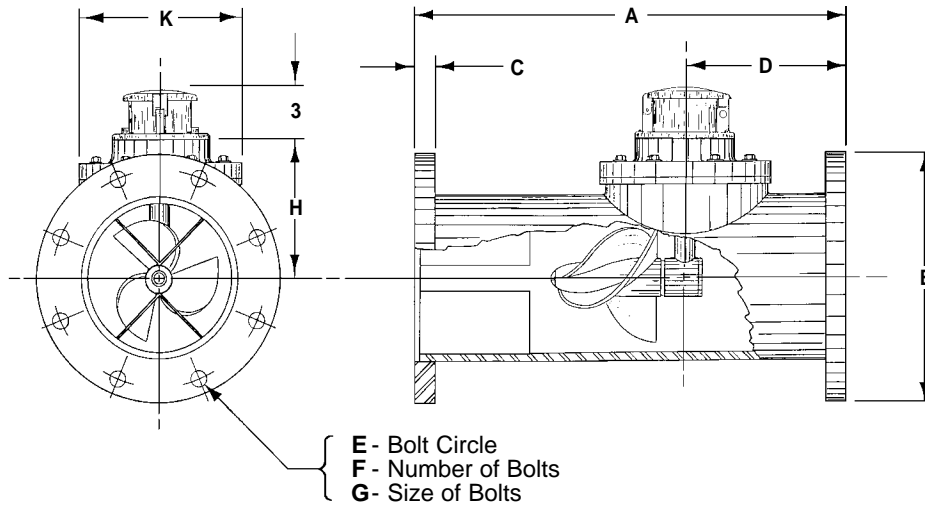

METER & PIPE SIZE	*LOW VELOCITY CONSTRUCTION MIN. - MAX.	FLOW RANGES, GPM STANDARD CONSTRUCTION MIN. - MAX. - INT.	HIGH VELOCITY CONSTRUCTION MIN. - MAX.	DIMENSIONS									SHIPPING WEIGHT POUNDS
				A	B	C	D	E	F	G	H	K	
2	N/A	40-160-225	N/A	18	6	5/8	7	4 3/4	4	5/8	5 1/4	9	70
3	40-250	45-250-350	N/A	18	7 1/2	5/8	7	6	4	5/8	5 1/4	9	70
4	50-500	55-500-700	200-700	18	9	5/8	7	7 1/2	8	5/8	5 1/4	9	80
6	90-1200	120-1200-1500	300-1500	22	11	11/16	9	9 1/2	8	3/4	6 1/4	9	120
8	100-1500	150-1500-2000	400-2500	24	13 1/2	11/16	9	11 3/4	8	3/4	7 1/4	9	150
10	125-2000	180-2000-3000	500-3500	26	16	11/16	10	14 1/4	12	7/8	8 1/2	11	200
12	150-2800	200-3000-3500	800-5000	28	19	13/16	10	17	12	7/8	9 1/2	11	250
14	250-3750	300-4000-4500	1000-6000	42	21	15/16	12	18 3/4	12	1	10 1/2	13 1/2	350
16	350-4750	400-5000-6000	1200-7500	48	23 1/2	1	12	21 1/4	16	1	11 1/2	13 1/2	570
18	450-5625	700-6000-7500	1500-9000	54	25	1 1/16	15	22 3/4	16	1 1/8	12 1/2	13 1/2	665
20	550-6875	850-8000-9000	2000-12000	60	27 1/2	1 1/8	15	25	20	1 1/8	13 1/2	13 1/2	780
24	800-10000	1000-10000-13500	3000-15000	72	32	1 1/4	18	29 1/2	20	1 1/4	17 1/2	21	1250
30	1200-15000	1800-15000-21000	4000-25000	84	38 3/4	1 3/8	18	36	28	1 1/4	20 1/2	21	2010
36	1500-20000	2000-20000-30000	5000-35000	96	46	1 5/8	20	42 3/4	32	1 1/2	23 1/2	21	2840
42	2000-28000	3000-30000-40000	6000-50000	96	53	1 3/4	24	49 1/2	36	1 5/8	28	32	4300
48	2500-35000	5500-35000-50000	7000-60000	96	59 1/2	1 7/8	24	56	44	1 5/8	31	32	4730

Standard construction will be supplied for all main line meters unless special flow range, materials, or construction are required.

\* Low velocity (LV) construction has the same low and maximum flow rates as AWWA C704.



Visit our Website: [www.mccrometer.com](http://www.mccrometer.com)  
 E-Mail: [info@mccrometer.com](mailto:info@mccrometer.com)

3255 WEST STETSON AVENUE • HEMET, CALIFORNIA 92545-7799 USA  
 TEL: 909-652-6811 • FAX: 909-652-3078

Copyright © 2001 McCrometer. All printed material should not be changed or altered without permission of McCrometer. The published technical data and instructions are subject to change without notice. Contact your McCrometer representative for current technical data and instructions.