

MODEL LP-04-D

150 psi FLANGED TUBE METER
 SOLID STATE ELECTRONIC PROPELLER METER
 STRAP-ON SADDLE
 DIGITAL INDICATOR-TOTALIZER
 SIZES 4" thru 16"

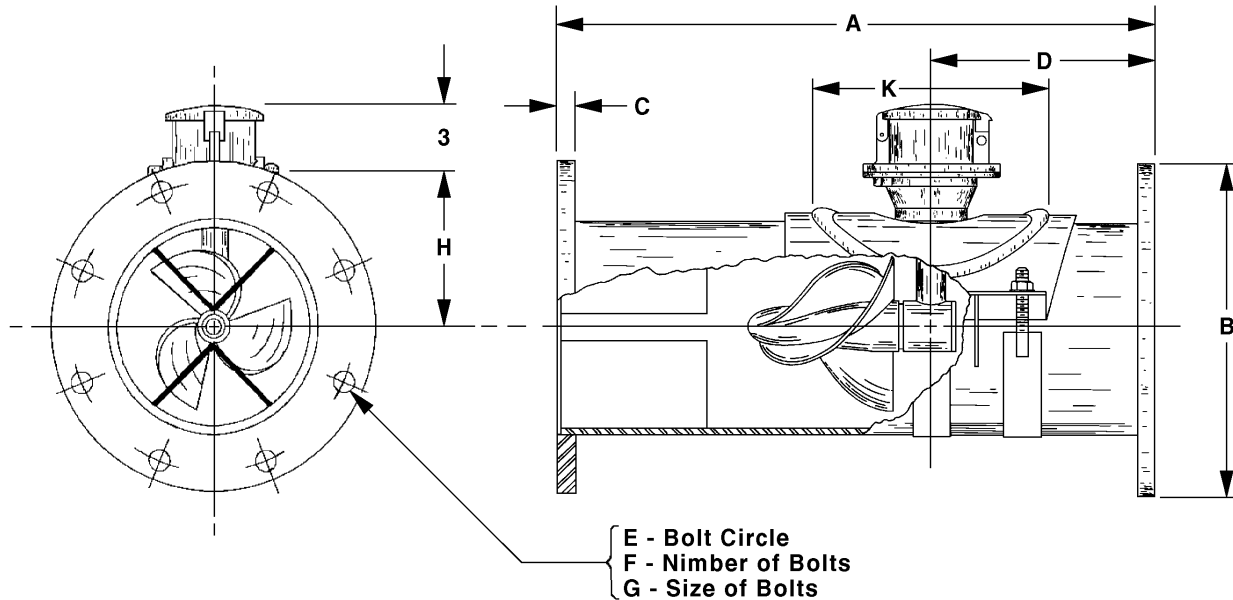

METER & PIPE SIZE	FLOW RANGES, GPM			DIMENSIONS									SHIPPING WEIGHT POUNDS
	MIN.	MAX.	INT.	A	B	C	D	E	F	G	H	K	
4	80	500	700	18	9	5/8	7	7½	8	5/8	5 ³ / ₁₆	12	122
6	200	1200	1500	22	11	11/16	9	9½	8	3/4	5¼	12	141
8	250	1500	2000	24	13½	11/16	9	11¾	8	3/4	6¼	12	161
10	300	2000	3000	26	16	11/16	10	14¼	12	7/8	7 ³ / ₈	12	195
12	350	3000	3500	28	19	13/16	10	17	12	7/8	8 ³ / ₈	12	225
14	450	4000	4500	42	21	15/16	12	18¾	12	1	9	12	300
16	500	5000	6000	48	23½	1	12	21¼	16	1	10	12	350