

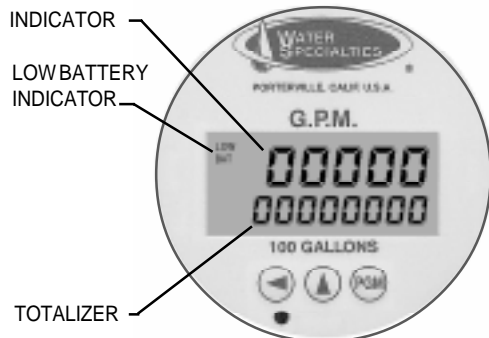

MODEL VF-28-D
 VERTICAL UPFLOW METER
 SOLID STATE ELECTRONIC PROPELLER METER
 DIGITAL INDICATOR - TOTALIZER
 SIZES 4" thru 20"



TYPICAL
 DIGITAL INDICATOR-TOTALIZER



DESCRIPTION

MODEL VF-28-D VERTICAL UPFLOW METERS are designed to meet AWWA specifications. The bolt-on design permits use in a wide range of applications with up to 150 psi working pressure. The mounting flange conforms to ANSI class 125 drilling. It is necessary, upon ordering, to furnish the I.D. dimension of the pipe the meter is to be mounted on for calibration purposes.

INSTALLATION is made by bolting the meter assembly to an appropriate cast iron or fabricated steel tee. These tees usually replace an elbow in existing systems such as on the suction or discharge side of a centrifugal pump of laterals in irrigation systems. The meter must have a full flow of liquid for proper accuracy. Fully opened gate valves, fittings, or other obstructions that tend to set up flow disturbances should be a minimum of ten pipe diameters upstream and one pipe diameter downstream from the meter. Installations with less than ten pipe diameters of straight pipe require straightening vanes. Meters with straightening vanes require at least five pipe diameters upstream and one pipe diameter downstream from the meter. An optional kit of adapters with up to 100 feet of cable is available to locate the indicator-totalizer at remote locations.

PROPELLER is magnetically coupled with the electronic sensor through the sealed drop-pipe. This completely eliminates water entering the meter assembly, as well as the need for any packing gland. The propeller is a conical shaped three bladed propeller, injection molded of thermoplastic material resistant to normal water corrosion and deformity due to high flow velocities.

BEARING in propeller is a water lubricated ceramic sleeve bearing that rides on a ceramic coated stainless steel spindle. Dual ceramic thrust bearings, standard on all meters, handle flows in both forward and reverse directions. The bearing design promotes extended periods of maintenance free propeller operation. Bearings within the sealed meter mechanism are shielded precision stainless steel bearings and are factory lubricated for the life of the meter.

DIGITAL INDICATOR-TOTALIZER has a non-volatile EEPROM memory to store totalizer count (updated every 60 minutes while running). The indicator dial can be furnished in GPM, CFS, MGD or any standard liquid measuring units with a choice of totalizer measuring units. The display is programmable to update from 0.5 to 5 seconds, and timeout from 1 to 9999 seconds.

INDICATOR (rate) FUNCTION is a five digit indicator with .35" tall numbers, programmable with 0 to 4 decimal point place with 0.0001 to 9999 rate scaling factor. The calculation method is $1/\text{Tau}$; programmable smoothing of 0 to 99%; rate zero time of 8 seconds.

TOTALIZER FUNCTION is an eight digit totalizer with .20" tall numbers, programmable with 0 to 4 decimal places, and a total scaling factor of 0.0001 to 9999. The totalizer can be reset from the front panel or disabled permanently.

SPECIFICATIONS

ACCURACY	Plus or minus 2% of actual flow within the range specified for each meter size.
PRESSURE RANGE	Up to 150 PSI maximum working pressure.
TEMPERATURE RANGE	140° F Maximum. Consult factory for special construction for higher temperatures.
MINIMUM FLOWS	As shown for each meter size and construction are required for accurate registration. See flow chart. NOTE: Minimum flow will be higher when auxiliary equipment is added.
MAXIMUM FLOWS	As shown for each meter size and construction are required for accurate registration. See flow chart.
INTERMITTENT FLOWS	As shown for each meter size are rated for 10% to 15% of the total time the meter is operating. Consult factory for High Velocity construction when intermittent flows are higher than shown on flow chart and/or when longer operating periods are required.
MATERIALS	Used in construction are chosen to minimize the corrosive effects of the liquids measured by the meter assembly. MAGNETS - permanent ceramic type INTERIOR BEARINGS - shielded stainless steel PROPELLER BEARING - ceramic sleeve type PROPELLER SPINDLE - ceramic coated stainless steel PROPELLER - injection molded thermoplastic DROP-PIPE - stainless steel SEPARATOR - stainless steel BOLTS - stainless steel METER HEAD - cast iron or fabricated steel, fusion epoxy coated.
OPTIONAL EQUIPMENT	Remote mounting kit, with up to 100 feet of cable, digital transmitter, and a wide range of controls and instruments for indicating, totalizing, and recording flow data for each meter. Special constructions and materials are available upon request.
ORDERING INFO	Must be specified by the customer and includes: minimum & maximum flow ranges, temperature of meter environment, indicator scale and units, totalizer dial units, type of materials and construction, I.D. of pipe and optional equipment desired.

MODEL VF-28-D
 VERTICAL UPFLOW METER
 SOLID STATE ELECTRONIC PROPELLER METER
 DIGITAL INDICATOR-TOTALIZER
 SIZES 4" thru 20"

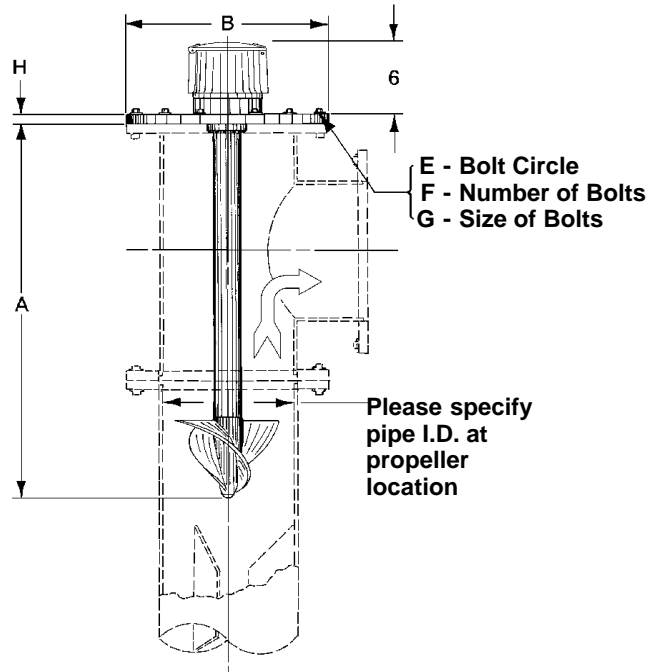

METER & PIPE SIZE	FLOW RANGES, GPM			DIMENSIONS						SHIPPING WEIGHT POUNDS
	MIN.	MAX.	INT.	A	B	E	F	G	H	
4	55	500	700	30	9	7½	8	5/8	5/8	60
6	130	1200	1500	30	11	9½	8	3/4	11/16	75
8	170	1500	2000	30	13½	11¾	8	3/4	11/16	90
10	200	2000	3000	30	16	14¼	12	7/8	11/16	110
12	220	3000	3500	30	19	17	12	7/8	13/16	140
14	320	4000	4500	32	21	18¾	12	1	15/16	175
16	420	5000	6000	36	23½	21¼	16	1	1	200
18	720	6000	7500	38	25	22¾	16	1 1/8	1 1/16	230
20	870	8000	9000	42	27½	25	20	1 1/8	1 1/8	260

WATER SPECIALTIES CORPORATION

Visit our Website – www.waterspecialties.com

191 WEST POPLAR AVENUE • PORTERVILLE, CALIFORNIA 93257-5311 U.S.A.
 PHONE: 559-784-3544 • U.S.A. FAX: 800-800-8804 • INTERNATIONAL FAX: 559-784-1787

Copyright © 2000 Water Specialties Corporation. All printed material should not be changed or altered without permission of Water Specialties. The published technical data and instructions are subject to change without notice. Contact your Water Specialties representative for current technical data and instructions.