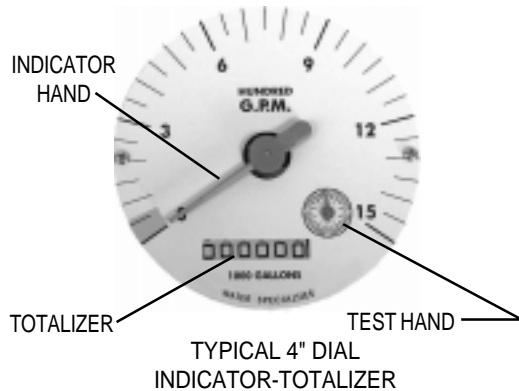

**MODEL VF-30**

VERTICAL UPFLOW TEE TUBE METER  
SEALED METER MECHANISM - MAGNETIC DRIVE  
INDICATOR - TOTALIZER  
SIZES 4" thru 20"

**DESCRIPTION**

**MODEL VF-30 VERTICAL UPFLOW TEE TUBE METERS** are designed to meet AWWA specifications. The flanged end tee design permits use in a wide range of applications with up to 150 psi working pressure. The base and side outlets are 150 lb. AWWA class D flat face steel flanges. Fabricated steel meter tubes have straightening vanes and are protected internally and externally with 12-15 mils of NSF approved, fusion epoxy resin.

**INSTALLATION** is made to any vertical discharge line with the proper size flange connection or to vertical discharge concrete turnouts with the proper anchor bolts. The meter must be installed upright for a full flow of liquid through the pipe to assure proper accuracy. Fully opened gate valves, fittings or other obstructions that tend to set up flow disturbances should be a minimum of five pipe diameters upstream and one pipe diameter downstream from the meter.

**PROPELLER** is magnetically coupled with the drive mechanism through the sealed separator assembly. This completely eliminates water entering the meter assembly, as well as the need for any packing gland. The propeller is a conical shaped three bladed propeller, injection molded of thermoplastic material resistant to normal water corrosion and deformity due to high flow velocities.

**BEARING** in propeller is a water lubricated ceramic sleeve and spindle bearing system with a ceramic/stainless steel spindle. Dual ceramic thrust bearings, standard on all meters, handle flows in both forward and reverse directions. The bearing design promotes extended periods of maintenance free propeller operation. Bearings within the sealed meter mechanism are shielded precision stainless steel bearings and are factory lubricated for the life of the meter.

**INDICATOR-TOTALIZER** is mechanically driven by the meter mechanism and features a full 4" diameter, 250 degree sweep dial with a six digit, straight reading type totalizer and sweep test hand. The indicator drive mechanism is temperature compensated so the indicator will be accurate at all points on the dial when operated between 32° and 140° F. The indicator dial can be furnished in GPM, CFS, MGD or any standard liquid measuring units with choice of standard totalizer measuring units. The bonnet, with padlock hasp, is o-ring sealed to the meter head.

**CHANGE GEARS** may be easily exchanged in the field when changing the dial, or when recalibrating for different pipe sizes. It is not necessary to remove pressure from the line for these changes.

**O-RING SEALS** are used at the meter head and all points where seals are required, making the meter mechanism completely immune to any of the corrosive effects of atmospheric moisture or the liquids measured by the meter assembly.

**SPECIFICATIONS**

<b>ACCURACY</b>	Plus or minus 2% of actual flow within the range specified for each meter size.
<b>PRESSURE RANGE</b>	Up to 150 PSI maximum working pressure.
<b>TEMPERATURE RANGE</b>	140° F Maximum. Consult factory for special construction for higher temperatures.
<b>MINIMUM FLOWS</b>	As shown for each meter size and construction are required for accurate registration. See flow chart. NOTE: Minimum flow will be higher when auxiliary equipment is added.
<b>MAXIMUM FLOWS</b>	As shown for each meter size and construction are rated for continuous operation. See flow chart.
<b>INTERMITTENT FLOWS</b>	As shown for each meter size are rated for 10% to 15% of the total time the meter is operating. Consult factory for High Velocity construction when intermittent flows are higher than shown on flow chart and/or when longer operating periods are required.
<b>MATERIALS</b>	Used in construction are chosen to minimize the corrosive effects of the liquids measured by the meter assembly. MAGNETS - permanent ceramic type INTERIOR BEARINGS - shielded stainless steel PROPELLER BEARING - ceramic sleeve type PROPELLER SPINDLE - ceramic coated stainless steel PROPELLER - injection molded thermoplastic DROP-PIPE - stainless steel SEPARATOR - stainless steel SHAFTS AND BOLTS - stainless steel METER HEAD - cast iron , fusion epoxy coated. METER TUBE - fabricated steel with 12-15 mils of NSF approved, fusion epoxy resin.
<b>OPTIONAL EQUIPMENT</b>	A meter mounted Forward & Reverse Totalizer, Totalizer Extensions and a wide range of controls and instruments for indicating, totalizing, and recording flow data for each meter. Special constructions and materials are available upon request.
<b>ORDERING INFO</b>	Must be specified by the customer and includes: minimum & maximum flow ranges, temperature of meter environment, indicator scale and units, totalizer dial units, type of materials and construction and optional equipment desired.

**MODEL VF-30**  
 VERTICAL UPFLOW TEE TUBE METER  
 SEALED METER MECHANISM - MAGNETIC DRIVE  
 INDICATOR - TOTALIZER  
 SIZES 4" thru 20"

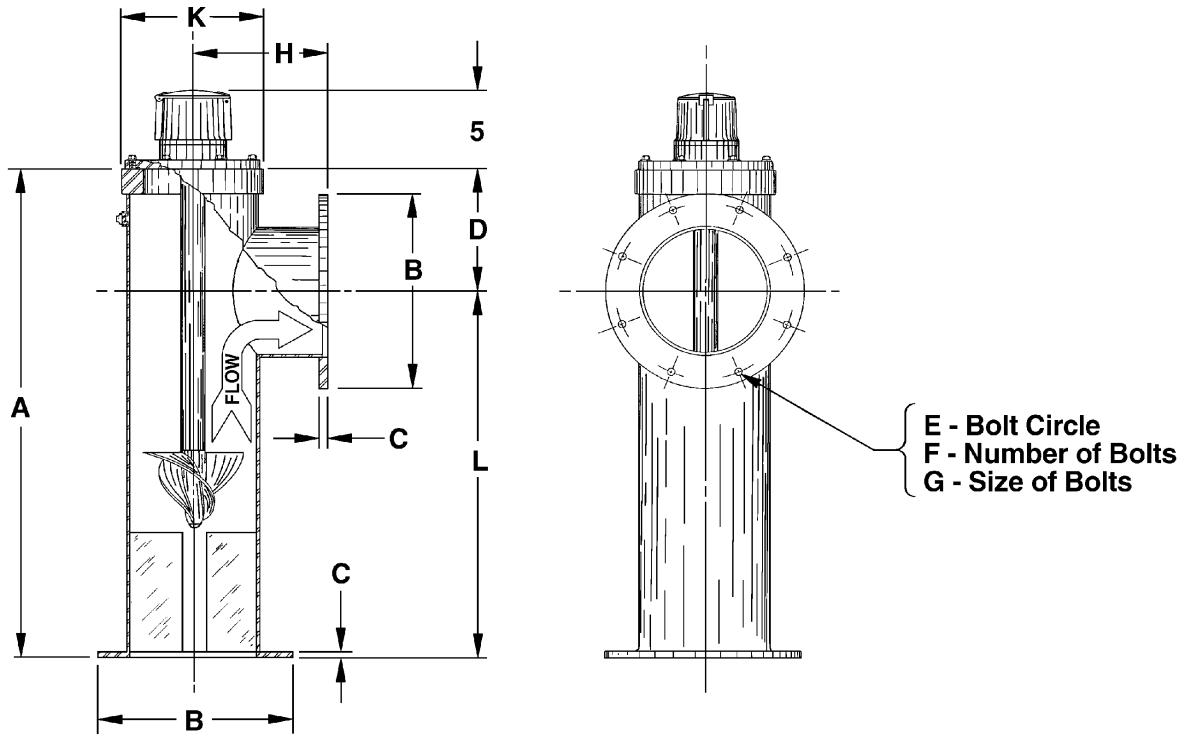

METER & PIPE SIZE	FLOW RANGES, GPM			DIMENSIONS										SHIPPING WEIGHT POUNDS
	MIN.	MAX.	INT.	A	B	C	D	E	F	G	H	K	L	
4	55	500	700	18	9	5/8	4 1/2	7 1/2	8	5/8	5	6	13 1/2	180
6	130	1200	1500	40	11	11/16	10	9 1/2	8	3/4	9	11	30	190
8	170	1500	2000	40	13 1/2	11/16	10	11 3/4	8	3/4	10	11	30	240
10	200	2000	3000	40	16	11/16	10	14 1/4	12	7/8	11	11	30	330
12	220	3000	3500	40	19	13/16	10	17	12	7/8	12	11	30	440
14	320	4000	4500	40	21	15/16	10	18 3/4	12	1	14	11	36	520
16	420	5000	6000	54	23 1/2	1	11 1/2	21 1/4	16	1	15	11	42 1/2	620
18	720	6000	7500	60	25	11/16	12	22 3/4	16	1 1/8	18	11	48	720
20	870	8000	9000	66	27 1/2	1 1/8	14	25	20	1 1/8	20	11	52	820

**WATER SPECIALTIES**

3255 WEST STETSON AVENUE • HEMET, CALIFORNIA 92545-7799 USA  
 TEL: 909-652-0591 • FAX: 909-652-5592

Visit our Website: [www.waterspecialties.com](http://www.waterspecialties.com)  
 E-Mail: [info@waterspecialties.com](mailto:info@waterspecialties.com)

Copyright © 2001 Water Specialties. All printed material should not be changed or altered without permission of Water Specialties. The published technical data and instructions are subject to change without notice. Contact your Water Specialties representative for current technical data and instructions.